



Questions are for both triple and combined science students
unless indicated in the question

Q1.

Potato blight is a disease of potato plants.

Potato blight is caused by the fungus *Phytophthora infestans*.

(a) What is the genus of the fungus that causes potato blight? Tick

(✓) one box.

Infestans

Phytophthora

Phytophthora infestans

(1)

(b) The fungus grows near the surface of the potato.

How does growing near the surface help the fungus to respire? Tick

(✓) one box.

The fungus can get nitrogen from the soil.

The fungus can get oxygen from the air.

The fungus can get water from the potato.

(1)

A farmer sprays his potato plants with a pesticide.

The pesticide kills the fungus that causes potato blight.

Spraying the crop with a pesticide could decrease biodiversity in a river flowing through his farm.

(c) What does 'biodiversity in a river' mean?

Tick (✓) one box.

The variety of species of animals in the river.

The variety of species of organisms in the river.

The variety of species of plants in the river.

(1)

- (d) The farmer sprayed pesticide on his potato plants. The next day it rained heavily.

Explain why the biodiversity in the river decreased.

(2)

Another method of preventing potato blight is to breed potatoes that are resistant to blight.

Resistance to potato blight is controlled by two alleles:

R = a dominant allele for having resistance to blight.

r = a recessive allele for not having resistance to blight.

A scientist crosses two potato plants. Each plant has the genotype Rr.

- (e) Complete the diagram below to show the possible genotypes of the offspring produced.

		Male gametes	
		R	r
Female gametes	R	RR	
	r		

(2)

- (f) Draw a ring around one of the homozygous genotypes in the diagram above.

(1)

- (g) What percentage of the offspring in the diagram will be resistant to potato blight?

Tick (✓) one box.

25% 50% 75% 100%

(1)

(h) Potatoes can also reproduce asexually.

Potatoes from one plant can be planted in the ground to produce new potato plants.

All the new plants from a parent plant that is resistant to blight will also be resistant to blight.

Explain why.

(2)

(Total 11 marks)

Q2.

The nucleus of a cell contains DNA.

(a) Name the structures inside the cell nucleus that contain DNA.

(1)

Figure 1 shows part of a DNA molecule.

Figure 1

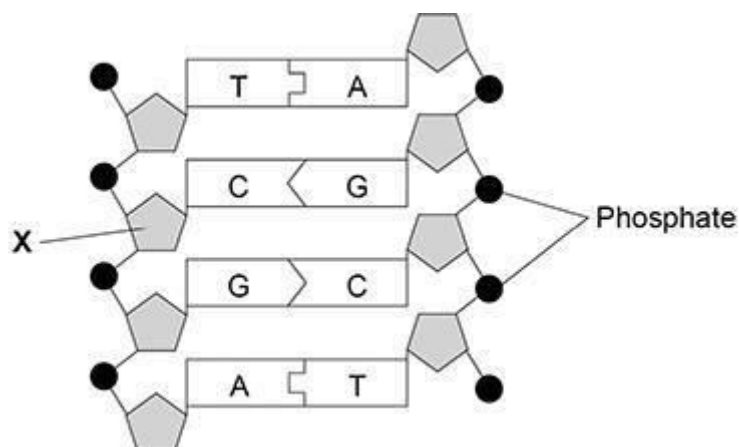

- (b) Name the part of the DNA molecule labelled X. **(triple only)**

(1)

- (c) What type of substances are labelled A, C, G and T in Figure 1? **(triple only)**

(1)

Figure 2 shows another section of a DNA molecule.

Figure 2

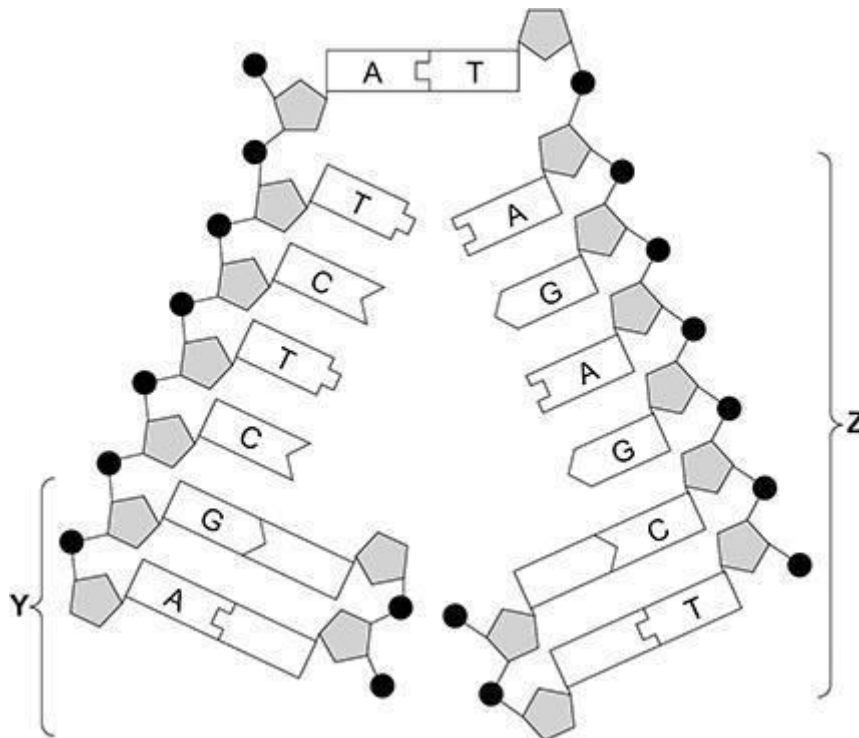

- (d) Four of the substances you named in part (c) are not labelled in part Y of Figure 2.

Label each of these substances with the correct letter, A, C, G or T.

Use information from other parts of Figure 2 to help you. **(triple only)**

(1)

- (e) What is happening to the DNA in part Z of Figure 2? Tick

(✓) one box. **(triple only)**

Differentiation

Evolution

Fertilisation

Replication

(1)

(f) A gene is a length of DNA.

What type of substance does a gene code for? **(triple only)**

(1)

(g) Most human body cells contain 6×10^{-12} grams of DNA.

What mass of DNA will a human sperm cell contain? Tick

(✓) one box. **(triple only)**

6×10^{-6} grams

6×10^{-12} grams

3×10^{-6} grams

3×10^{-12} grams

(1)

(h) What is the name of the type of cell division that produces sperm cells? Tick

(✓) one box.

Binary fission

Differentiation

Meiosis

Mitosis

(1)

(Total 8 marks)

Q3.

Sickle cell anaemia is an inherited condition that affects red blood cells.

Sickle cell anaemia is caused by a mutation in the gene for haemoglobin. Haemoglobin is the red pigment found in red blood cells.

A person who is homozygous for the normal haemoglobin allele (H^A) produces normal red blood cells.

A person who is homozygous for the mutated allele (H^S):

- produces red blood cells with abnormal haemoglobin
- has red blood cells that can form an altered shape
- has sickle cell anaemia and becomes ill.

A person who is heterozygous:

- has both normal and abnormal haemoglobin in the red blood cells
- has sickle cell trait
- is generally healthy but can become ill in certain circumstances.

- (a) Give the reason why a mutation in the gene coding for haemoglobin could be harmful.

(1)

- (b) Figure 1 shows some red blood cells from the blood of a person with sickle cell trait.

Figure 1



Calculate the proportion of cells in Figure 1 that have an altered shape.





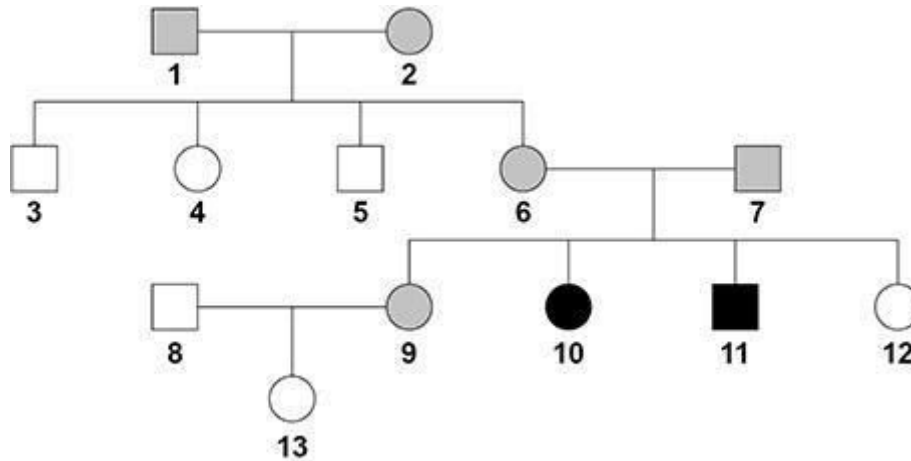

Proportion = _____

(2)

Figure 2 shows the inheritance of sickle cell anaemia in one family.

Figure 2

Key

-  Unaffected male
-  Unaffected female
-  Male with sickle cell anaemia
-  Female with sickle cell anaemia
-  Male with sickle cell trait
-  Female with sickle cell trait

- (c) Persons 8 and 9 in Figure 2 are expecting a second child.

Determine the probability that the child will be a girl with sickle cell trait.

You should:

- draw a Punnett square diagram
- identify the phenotype of each offspring genotype
- use the symbols:
 H^A = normal haemoglobin allele
 H^S = mutated haemoglobin allele.

Probability of a girl with sickle cell trait = _____

(5)

- (d) Without medical treatment, people with sickle cell anaemia are frequently ill and have a reduced life expectancy.

The malarial parasite cannot live in the red blood cells of a person who has the H^S allele.

A scientist stated:

'It is an advantage for people to have the H^S allele in countries where malaria occurs.'

Evaluate the scientist's statement.

(3)

(Total 11 marks)

Q4.

Sperm cells and egg cells are formed by meiosis.

- (a) During meiosis a cell divides twice.

How many sperm cells are formed when a cell divides by meiosis?

(1)

- (b) Human body cells contain 46 chromosomes.

How many chromosomes are in each human egg cell?

(1)

Dupuytren's is a disorder that affects the hands.

One form of Dupuytren's is caused by a dominant allele (D).

The allele for not having Dupuytren's is recessive (d).

(c) What is an allele?

Tick (✓) one box.

A different form of a chromosome

A different form of a gamete

A different form of a gene

(1)

(d) A man with Dupuytren's has the genotype Dd.

Which word describes the man's genotype?

Tick (✓) one box.

Heterozygous

Homozygous

Phenotype

(1)

The man with Dupuytren's (Dd) and a woman who does not have Dupuytren's (dd) plan to have a child.

(e) Complete the genetic diagram in the figure below to show the possible genotypes of the child.

		Woman	
		d	d
Man	D	Dd	
	d		

(2)

(f) Draw a ring around the genotype of a child in the figure above who will have Dupuytren's.

(1)

(g) What is the chance of the child having Dupuytren's?

Tick (✓) one box.

25%

50%

75%

100%

(1)

(h) A genetic disorder develops as a result of a change in a gene. What scientific term describes a change in a gene?

(1)

(i) People with a family history of some genetic disorders are offered embryo screening.

Suggest one way embryo screening can help people with a family history of a genetic disorder.

(1)

(Total 10 marks)

Q5. **(triple only)**

This question is about DNA.

(a) Describe the shape of a DNA molecule. **(triple only)**

(2)

The below diagram shows part of a DNA molecule.

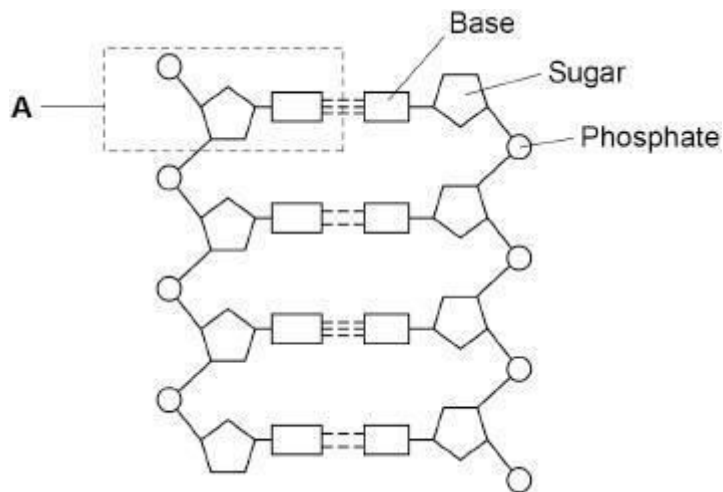

(b) DNA codes for a sequence of amino acids.

Which part of DNA forms the code for a particular amino acid? Tick

(✓) one box. **(triple only)**

Bases

Phosphates

Sugars

(1)

(c) Which substance is produced when amino acids are joined together?

Tick (✓) one box. **(triple only)**

Carbohydrate

Fat

Protein

(1)

(d) DNA is made of repeating units. One of the units is labelled A in the diagram above.

What is the name of the repeating unit labelled A?

Tick (✓) one box.

(triple only)

Chromosome	<input type="checkbox"/>
Enzyme	<input type="checkbox"/>
Nucleotide	<input type="checkbox"/>

(1)

- (e) The DNA in one human body cell is the length of 6 000 million repeating units (part A).

Each repeating unit is 0.34 nanometres (nm) long.

Calculate the length of the DNA in the cell in millions of nanometres. **(triple only)**

Length = _____ million nm

(2)

- (f) Give your answer to question (e) in metres. 1

(triple only)

metre = 1×10^9 nanometres

Length = m

(1)

- (g) DNA analysis can show people which alleles they have.

Patients who have certain types of cancer can be offered DNA analysis. The family of the patient can also be offered DNA analysis.

Suggest one advantage of having DNA analysis. **(triple only)**

(1)

(Total 9 marks)

Q6. **(triple only)**

DNA is a polymer of nucleotides.

(a) Why is DNA described as a polymer? **(triple only)**

(1)

The diagram below shows part of a DNA molecule.

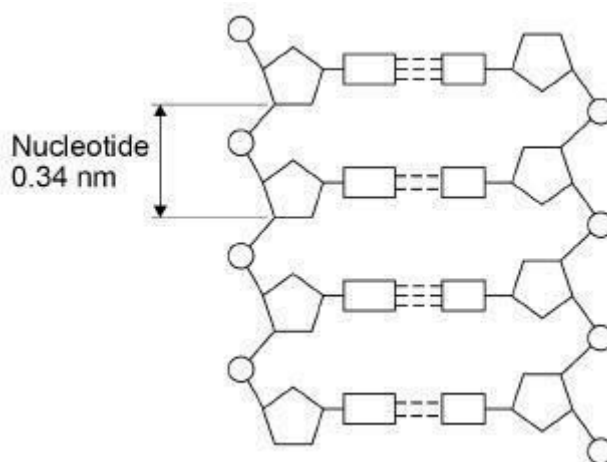

(b) Describe the structure of a nucleotide. **(triple only)**

(4)

(c) The length of a DNA double helix increases by 0.34 nm for every pair of nucleotides.

The total number of nucleotides in a human body cell is 1.2×10^{10} .

Calculate the total length of double helix in a human body cell.

Give your answer in metres. Use information from the diagram.

(triple only)

Total length = _____ m

(5)

(d) Some parts of DNA do not code for proteins. **(triple only)**

Describe how non-coding parts of DNA can affect the expression of genes.

(1)

(Total 11 marks)

Q7.

There are two types of cell division: mitosis and meiosis.

(a) Describe three differences between the processes of mitosis and meiosis. 1

2

 3

 (3)

(b) Describe one similarity between the processes of mitosis and meiosis.

 (1)

Dupuytren's is a disorder that affects the hands.

The diagram below shows the inheritance of Dupuytren's in one family.

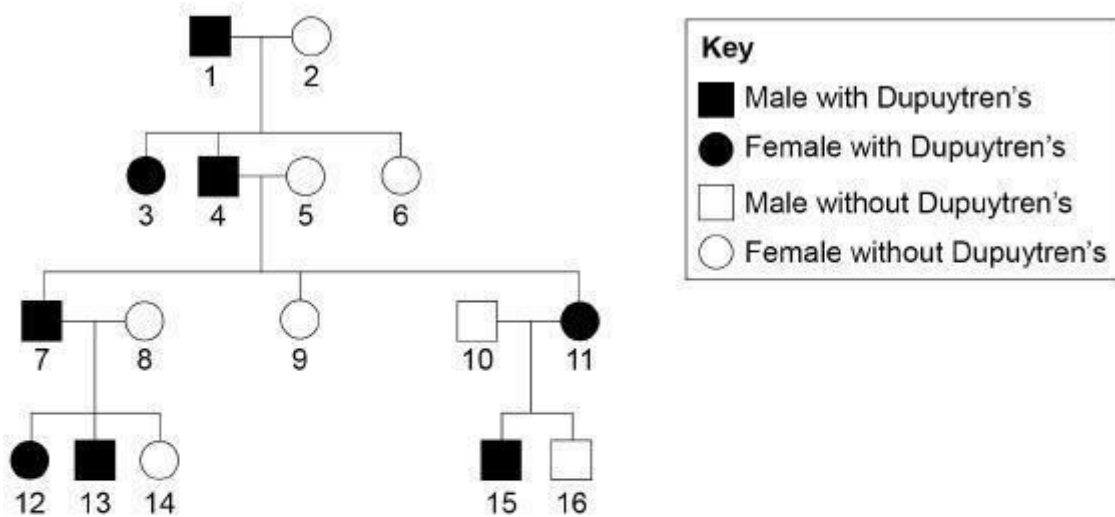

Dupuytren's is caused by a dominant allele in this family.

D = dominant allele

d = recessive allele

(c) Give the genotype of person 1.

Explain your answer. Genotype

 (2)

- (d) Person 7 and person 8 in the diagram above are expecting a fourth child. What is the probability of the child having Dupuytren's?

You should:

- draw a Punnett square diagram
- identify which offspring have Dupuytren's

Probability = _____

(5)

- (e) Explain how the diagram above shows the allele for Dupuytren's is not on the Y chromosome.

(2)

(Total 13 marks)

Q8.

The shape of a person's earlobes is controlled by a gene.

Figure 1 shows two types of earlobe.

Figure 1



Free earlobe



Attached earlobe

A dominant allele codes for free earlobes.

(a) What is a dominant allele?

Tick (✓) one box.

An allele expressed even if a person only has one copy of the allele

An allele expressed only if a person has two copies of the allele

An allele expressed only if a person has no recessive allele

An allele expressed only if it is inherited from the male parent

(1)

(b) A man with free earlobes and a woman with attached earlobes have children together.

Complete Figure 2 to show the possible genotypes of the children. Use the symbols:

E = allele for free earlobes

e = allele for attached earlobes

Figure 2

		Woman	
		e	e
Man	E	Ee	
	e		

(2)

(c) What is the probability that one of the children would have attached earlobes?

Use Figure 2.

Tick (✓) one box.

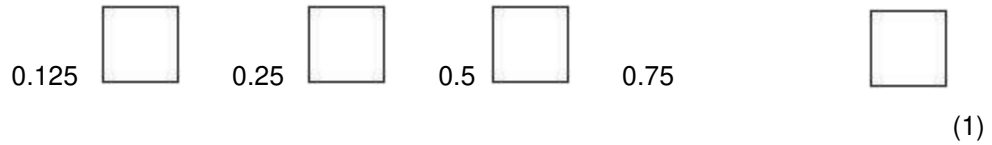

(d) Figure 3 shows the inheritance of the sex chromosomes, X and Y.

Complete Figure 3 to show the sex chromosomes in the gametes of the man and the woman.

Figure 3

	Woman	
	X	X
Man	X	X
	Y	Y

(2)

(e) Calculate the probability that the man and the woman's next child will be a girl with attached earlobes.

Use the equation:

probability of a girl with attached earlobes

= probability of attached earlobes × probability of being a girl

Probability of a girl with attached earlobes = _____

(2)

(Total 8 marks)

Q9.

Figure 1 shows the production of sperm cells in humans.

Figure 1

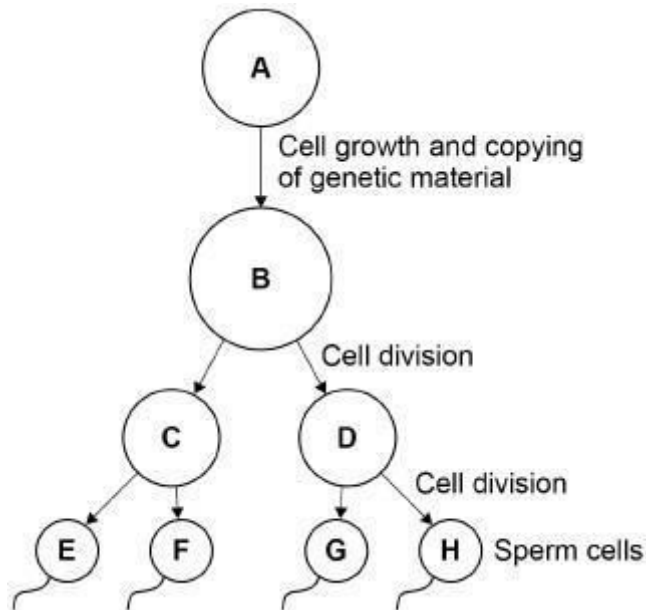

- (a) Cell A is a normal body cell.

How many chromosomes are there in cell A?

Tick (✓) one box.

23
 46
 48
 92

(1)

- (b) What is the mass of DNA in cell E?

Tick (✓) one box.

A quarter of the mass of the DNA in cell A

Half the mass of the DNA in cell A

The same mass as the DNA in cell A

Twice the mass of the DNA in cell A

(1)

- (c) What type of cell division produces sperm cells?

Tick (✓) one box.

- Binary fission
- Differentiation
- Meiosis

(1)

- (d) Sometimes there are errors in copying the genetic material.

What term describes an error in the genetic material?

Tick (✓) one box.

- Absorption
- Fertilisation
- Mitosis
- Mutation

(1)

- (e) A woman has three children, aged 4, 6 and 9 years.

Why are the children not genetically identical?

(2)

In sexual reproduction, a sperm cell fuses with an egg cell to form a new single cell.

An embryo develops from the single cell.

The cell divides three times to produce the embryo.

- (f) How many cells are there in the embryo after three cell divisions? Tick

(✓) one box.

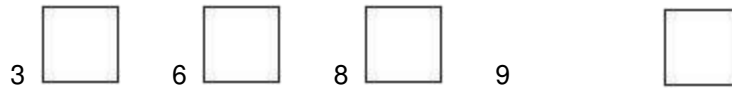

(1)

Figure 2 shows a different human embryo.

Figure 2



(g) Measure image length X on Figure 2.

Give your answer in millimetres (mm).

X = _____ mm

(1)

(h) The image in Figure 2 has been magnified $\times 500$

Calculate the real length of the embryo.

Use the equation:

$$\text{real length of the embryo} = \frac{\text{image length}}{\text{magnification}}$$

Give your answer in micrometres (μm).

1 mm = 1000 μm

Real length of the embryo = _____ μm

(3)

- (i) The embryo may not implant in the lining of the uterus.

The embryo will then be lost from the woman's body several days later.

Explain why the woman may not notice this has happened.

(2)

(Total 13 marks)

Q10.

Genetic material is made of DNA.

- (a) Which structures in the nucleus of a human cell contain DNA? **(triple only)**

(1)

Figure 1 shows part of one strand of a DNA molecule.

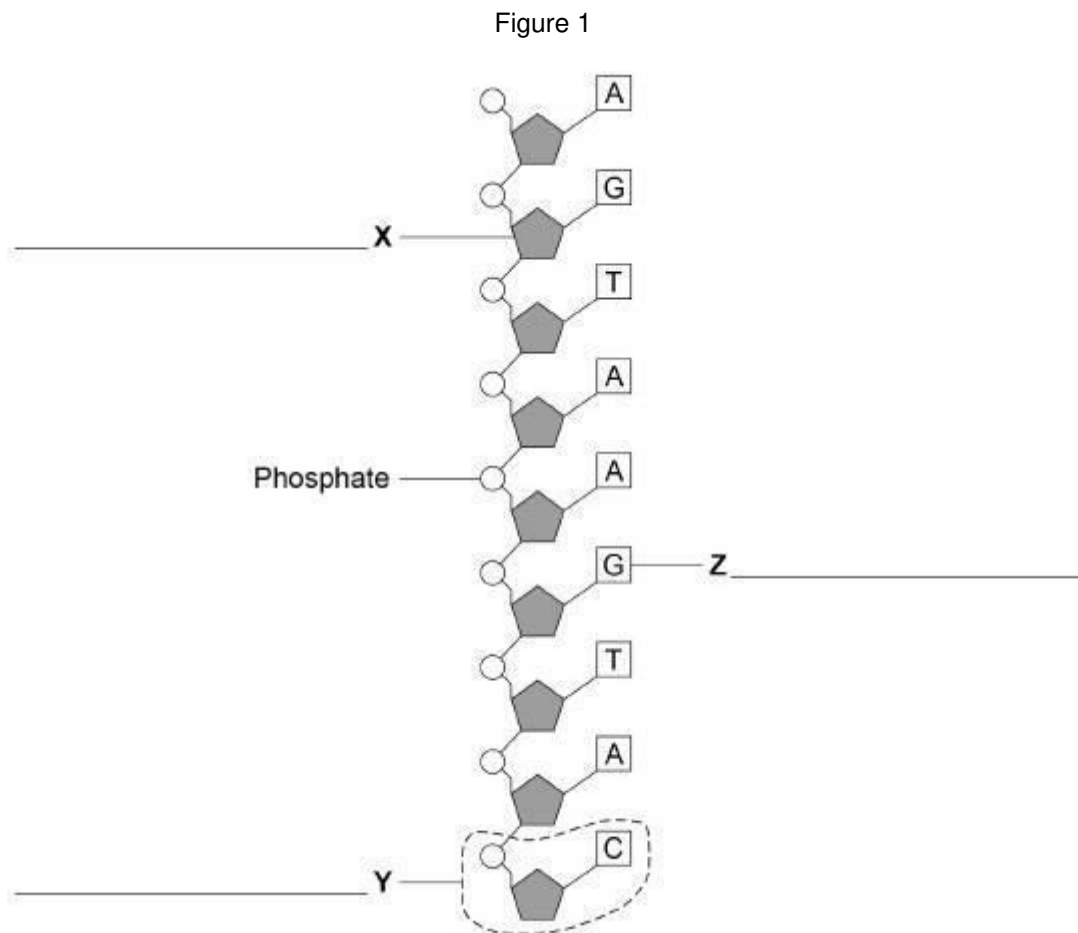

(b) Label parts X, Y and Z on Figure 1.

Choose answers from the box.

Base	Fatty acid	Nucleotide	Sugar	Glycerol
------	------------	------------	-------	----------

(3)

(c) A complete DNA molecule is made of two strands twisted around each other.

What scientific term describes this structure?

(triple only)

(1)

(d) DNA codes for the production of proteins.

A protein molecule is a long chain of amino acids.

How many amino acids could be coded for by the piece of DNA shown in Figure 1?

Tick (✓) one box. **(triple only)**

2	<input type="checkbox"/>	3	<input type="checkbox"/>	9	<input type="checkbox"/>	18	<input type="checkbox"/>
---	--------------------------	---	--------------------------	---	--------------------------	----	--------------------------

(1)

(e) Scientists have now studied the whole human genome. Give

two benefits of understanding the human genome.

1 _____

2 _____

(2)

(Total 8 marks)

Q11.

The following table gives the classification of four plant species.

Group	Species 1	Species 2	Species 3	Species 4
Kingdom	<i>Plantae</i>	<i>Plantae</i>	<i>Plantae</i>	<i>Plantae</i>
Phylum	<i>Spermatophyta</i>	<i>Spermatophyta</i>	<i>Spermatophyta</i>	<i>Spermatophyta</i>
Class	<i>Monocotyledonae</i>	<i>Dicotyledonae</i>	<i>Monocotyledonae</i>	<i>Dicotyledonae</i>
Order	<i>Poales</i>	<i>Fabales</i>	<i>Poales</i>	<i>Scrophulariales</i>
Family	<i>Cyperaceae</i>	<i>Fabaceae</i>	<i>Poaceae</i>	<i>Scrophulariaceae</i>

Genus	<i>Eriophorum</i>	<i>Pisum</i>	<i>Poa</i>	<i>Antirrhinum</i>
Species	<i>angustifolium</i>	<i>sativum</i>	<i>annua</i>	<i>majus</i>

(a) Species 1 and 3 are the most closely related.

What information in the table above gives evidence for this?

(1)

Figure 1 shows the inheritance of flower colour in two species of plant.

Figure 1

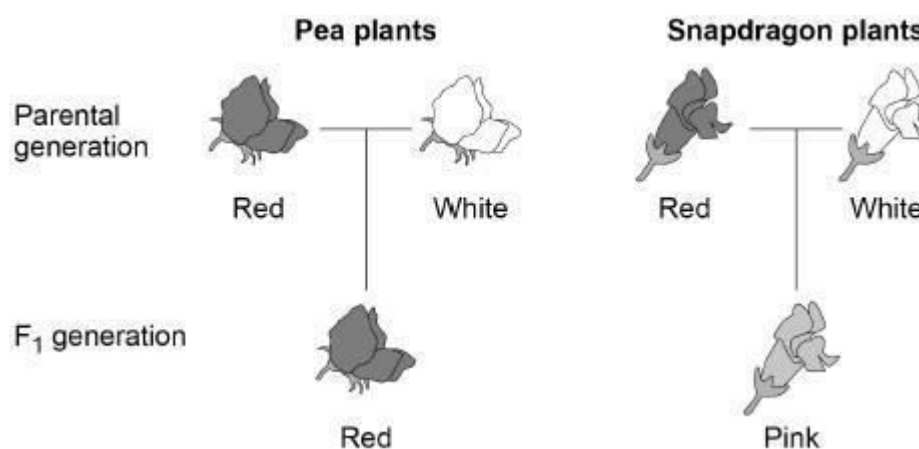

- In pea plants and in snapdragon plants, flower colour is controlled by one pair of alleles.
- In Figure 1 the parental generation plants are homozygous for flower colour.
- In heterozygous pea plants, the allele for red flower colour is dominant.
- In heterozygous snapdragon plants, the alleles for flower colour are both expressed.

Use the following symbols for alleles in your answers to parts (b) to (d):

Pea plants

R = allele for red flowers
r = allele for white flowers

Snapdragon plants

C^R = allele for red flowers
C^W = allele for white flowers

(b) What is the genotype of the red-flowered pea plants in the F₁ generation?

(1)

- (c) What is the genotype of a white-flowered snapdragon plant?

(1)

A gardener crossed two pink-flowered snapdragon plants.

- (d) Draw a Punnett square diagram to show why only some of the next generation plants had pink flowers.

Identify the phenotypes of all the offspring plants.

(3)

- (e) What percentage of the offspring would you expect to have pink flowers?

Percentage = _____%

(1)

Commercially, hundreds of pink-flowered snapdragon plants can be produced from one pink-flowered plant.

Figure 2 shows a tissue culture technique used for producing many plants from one plant.

Figure 2

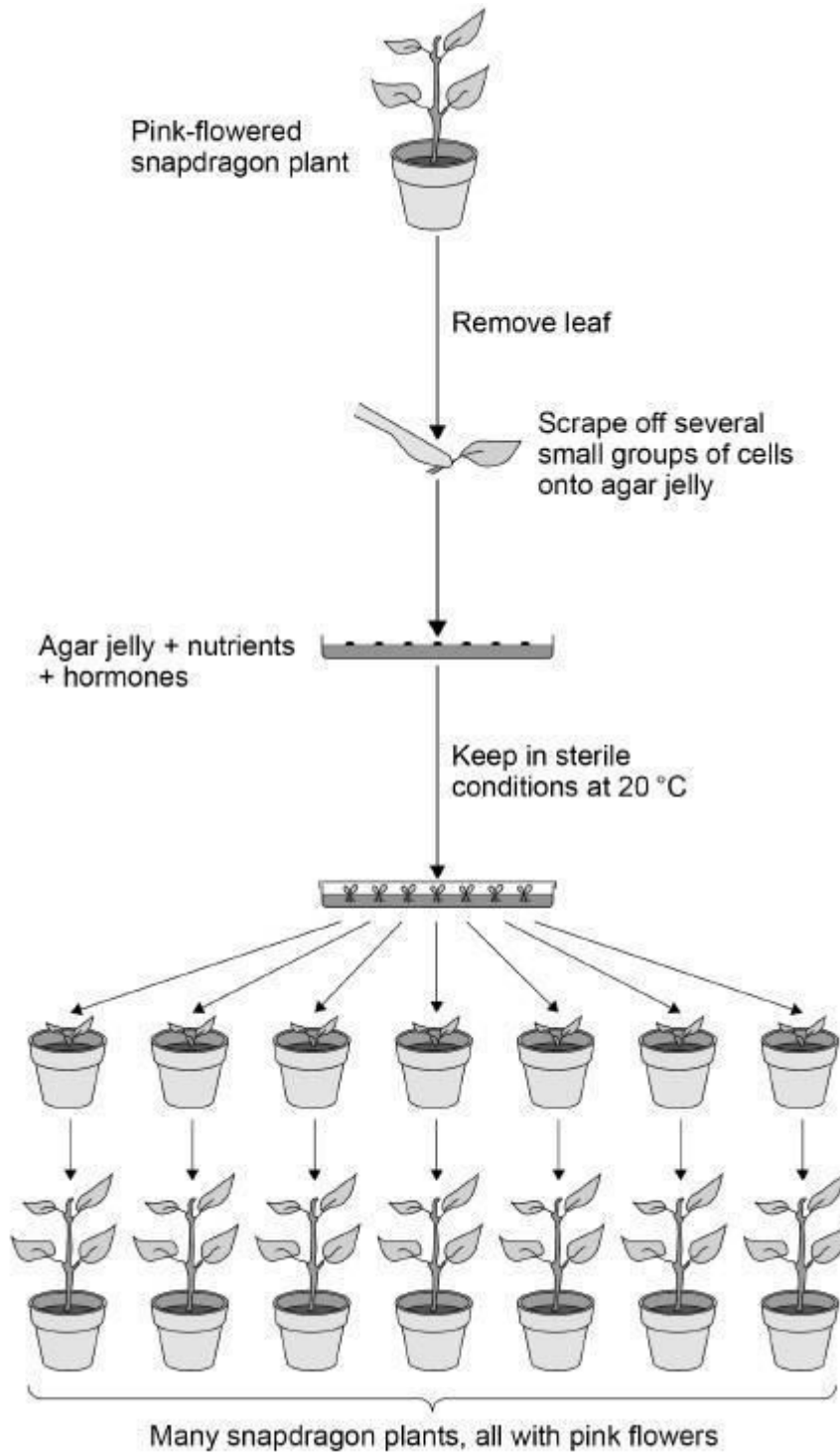

- (f) Give a reason for each of the following steps shown in Figure 2. **(triple only)** Several groups of cells are scraped off the leaf:

Nutrients are added to the agar jelly: _____

Hormones are added to the agar jelly: _____

The plant cells are kept in sterile conditions: _____

The plant cells are kept at 20 °C: _____

(5)

- (g) Explain why the method shown in Figure 2 produces only pink-flowered plants.

(2)

(Total 14 marks)

Q12.

This question is about the cell cycle.

- (a) Chromosomes are copied during the cell cycle.

Where are chromosomes found?

Tick one box.

Cytoplasm

Nucleus

Ribosomes

Vacuole

(1)

- (b) What is the name of a section of a chromosome that controls a characteristic?

(1)

Figure 1 shows information about the cell cycle.

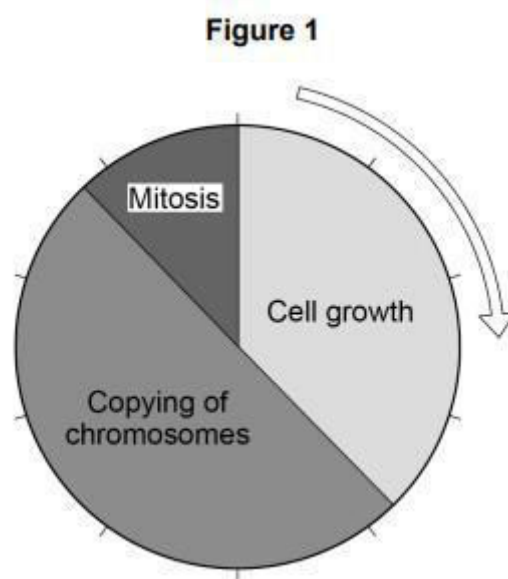

- (c) Which stage of the cell cycle in Figure 1 takes the most time? Tick one box.

Cell growth

Copying of chromosomes

Mitosis

(1)

- (d) During mitosis cells need extra energy.
Which cell structures provide most of this energy? Tick one box.

Chromosomes	<input type="checkbox"/>
Cytoplasm	<input type="checkbox"/>
Mitochondria	<input type="checkbox"/>
Ribosomes	<input type="checkbox"/>

(1)

- (e) The cell cycle in Figure 1 takes two hours in total. The cell growth stage takes 45 minutes.

Calculate the time taken for mitosis.

Time = _____ minutes

(2)

Figure 2 shows some cells in different stages of the cell cycle.

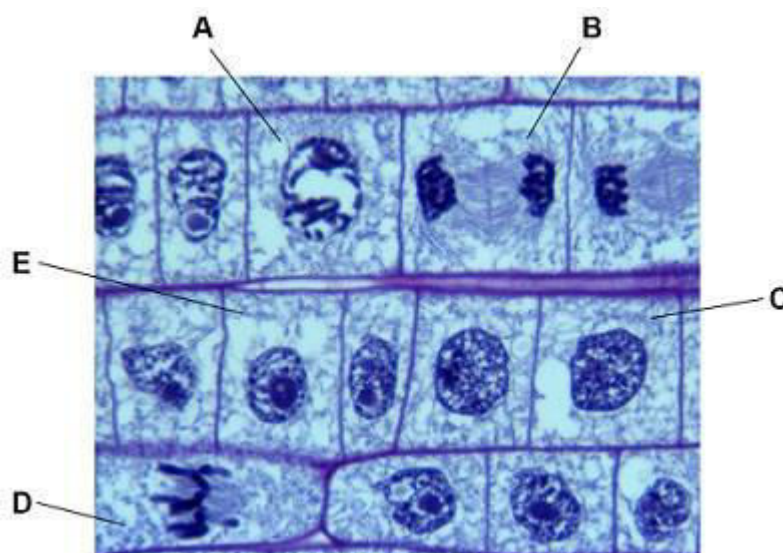

- (f) Which cell is not dividing by mitosis

Tick one box.

A	B	C	D
---	---	---	---

(1)

- (g) Cell E in Figure 2 contains 8 chromosomes. Cell E divides by mitosis.

How many chromosomes will each new cell contain? Tick one box.

2	<input type="checkbox"/>
4	<input type="checkbox"/>
8	<input type="checkbox"/>
16	<input type="checkbox"/>

(1)

- (h) Why is mitosis important in living organisms?

Tick one box.

To produce gametes	<input type="checkbox"/>
To produce variation	<input type="checkbox"/>
To release energy	<input type="checkbox"/>
To repair tissues	<input type="checkbox"/>

(1)

(Total 9 marks)

Q13.

In the mid-19th century, a scientist studied inheritance in pea plants.

The scientist's work was the beginning of our modern understanding of genetics.

- (a) What is the name of this scientist?

Tick one box.

Alfred Russel Wallace

Charles Darwin

Gregor Mendel

Jean-Baptiste Lamarck

(1)

- (b) In the mid-20th century, other scientists identified the chemical substance that makes up genetic material.

What is the name of the chemical substance that makes up genetic material?

Tick one box.

Carbohydrate

DNA

Lipid

Protein

(1)

- (c) A gene often has two alleles.

One allele is dominant and the other allele is recessive.

When is a recessive allele expressed as a characteristic?

Tick one box.

When the dominant allele is not present

When the recessive allele is inherited from the female parent

When the recessive allele is inherited from the male parent

When the recessive allele is present on only one of the chromosomes



(1)

A scientist investigated the inheritance of height in pea plants.

The scientist crossed tall pea plants with short pea plants.

Figure 1 shows the scientist's results.

Figure 1

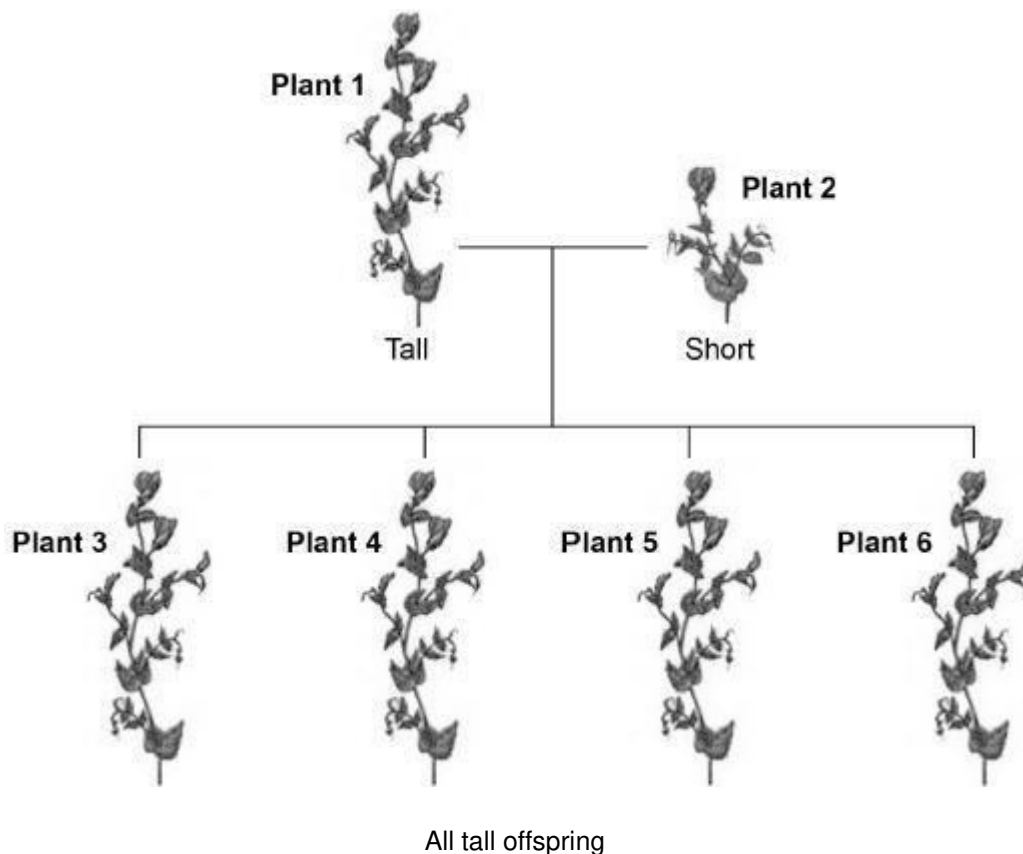

In questions (d) and (e), use the following symbols to represent alleles:

T = the dominant allele for tall.

t = the recessive allele for short.

(d) In Figure 1, the genotype of plant 1 is TT.

Give the genotype of plant 2.

(1)

(e) The scientist crossed plant 3 with plant 4.

Complete Figure 2 to show the offspring produced from this cross.

Figure 2

		Male gametes	
		T	t
Female gametes	T	TT	
	t		

(2)

- (f) Draw a circle around one of the homozygous offspring in Figure 2.

(1)

- (g) What is the ratio of tall plants : short plants in the offspring in Figure 2?

Ratio of tall plants : short plants = _____ : _____

(1)

(Total 8 marks)

Q14.

Cell division is needed for growth and for reproduction.

- (a) The table below contains three statements about cell division.

Complete the table.

Tick one box for each statement.

Statement	Statement is true for		
	Mitosis only	Meiosis only	Both mitosis and meiosis
All cells produced are genetically identical			
In humans, at the end of cell division each cell contains 23 chromosomes			
Involves DNA replication			

(2)

Bluebell plants grow in woodlands in the UK.

- Bluebells can reproduce sexually by producing seeds.
 - Bluebells can also reproduce asexually by making new bulbs.
- (b) One advantage of asexual reproduction for bluebells is that only one parent is needed.

Suggest two other advantages of asexual reproduction for bluebells. **(triple only)**

1. _____

2. _____

(2)

- (c) Explain why sexual reproduction is an advantage for bluebells. **(triple only)**

(4)

(Total 8 marks)

Q15.

Scientists want to breed cows that produce milk with a low concentration of fat.

Figure 1 shows information about the milk in one group of cows.

The cows were all the same type.

Figure 1

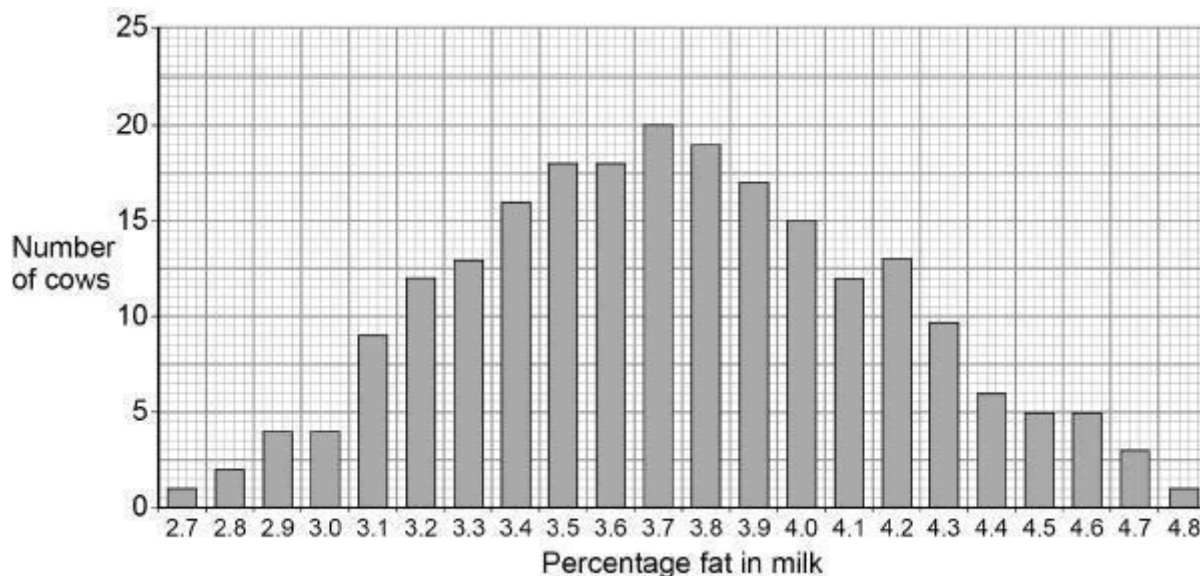

(a) In Figure 1 the mean percentage of fat in the milk is equal to the modal value.

Give the mean percentage of fat in the milk of these cows.

Mean percentage = _____

(1)

(b) A student suggested:

‘The percentage of fat in milk is controlled by one dominant allele and one recessive allele.’

How many different phenotypes would this produce? Tick

one box.

2	<input type="checkbox"/>
---	--------------------------

3	<input type="checkbox"/>
---	--------------------------

22	<input type="checkbox"/>
----	--------------------------

46	<input type="checkbox"/>
----	--------------------------

(1)

(c) Give the evidence from Figure 1 which shows the percentage of fat in the milk is controlled by several genes.

(1)

(d) One of the genes codes for an enzyme used in fat metabolism. A mutation in this gene causes a reduction in milk fat.

The mutation changes one amino acid in the enzyme molecule.

Explain how a change in one amino acid in an enzyme molecule could stop the enzyme working. **(triple only)**

(3)

The scientists found one cow with a mutation.

The cow's milk contained only 2.9% fat.

Figure 2 shows the percentage of fat in the milk of cattle related to the cow with the mutation.

The values for male cattle are the mean values of their female offspring.

Figure 2

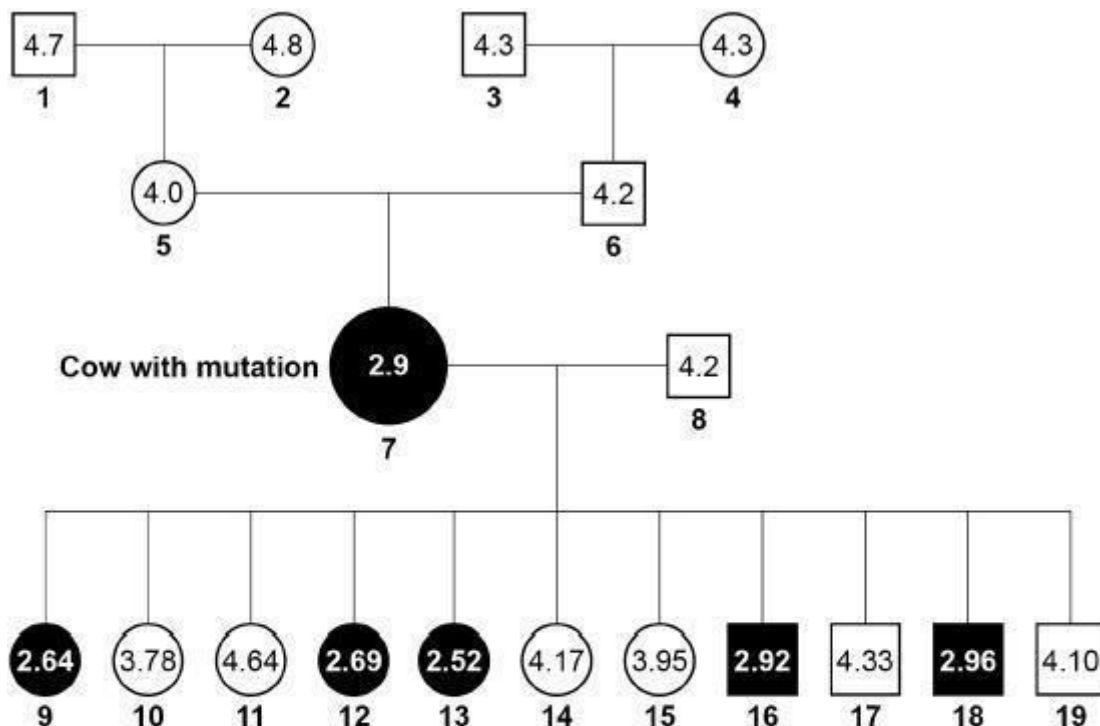

Key

- Female with low-fat milk
- Male whose female offspring have low-fat milk
- Female with high-fat milk
- Male whose female offspring have high-fat milk

(e) Animal 8 is homozygous.

The mutation in animal 7 produced a dominant allele for making low-fat milk.

Give evidence from Figure 2 that animal 7 is heterozygous.

(1)

(f) Animals 7 and 8 produced 11 offspring. These offspring were produced by in vitro fertilisation (IVF).

The embryos from IVF were transferred into 11 other cows.

Suggest why IVF and embryo transfer were used rather than allowing animals 7 and 8 to mate naturally.

(1)

Q16.

Chromosomes carry genetic information.

Chromosomes are found in nearly all human cells.

- (a) How many chromosomes are there in most human body cells? Tick one box.

 23

 24

 46

 48

(1)

- (b) How many chromosomes are there in a human gamete cell?

(1)

- (c) Complete the sentences.

Choose the answers from the box.

sexual reproduction	binary fission	egg	fertilisation	meiosis
mitosis	ovary	sperm	testis	uterus

The female gamete is called the _____.

The male gamete is called the _____.

The female gamete is produced in the _____.

Gametes are produced by a type of cell division

called _____.

Male and female gametes join together in a process

called _____.

(5)

In humans, the sex chromosomes are called X and Y.

The diagram shows the inheritance of sex chromosomes.

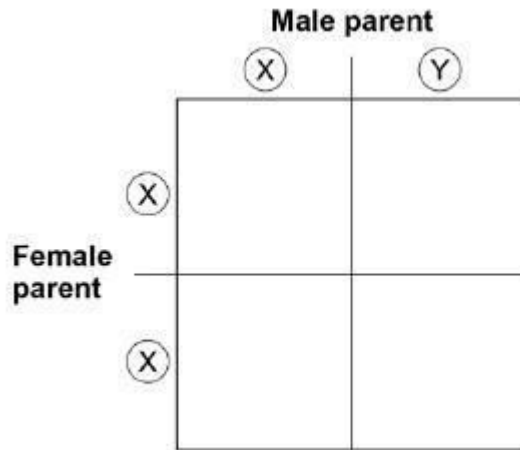

- (d) Complete the diagram above to show the sex chromosomes inherited by the offspring.

(2)

- (e) What is the chance that a child produced by these parents will be female? Tick one box.

1 in 2

1 in 3

1 in 4

3 in 4

(1)

- (f) The parents shown in the diagram above have five children.

Give two reasons why these children all look different from each other.

1. _____

2. _____

(2)
(Total 12 marks)

Q17.

In humans, chromosome X and chromosome Y are the sex chromosomes.

(a) Most cells in the human body contain two sex chromosomes.

Which type of cell does not have two sex chromosomes? Tick one box.

Liver cell	<input type="checkbox"/>
Muscle cell	<input type="checkbox"/>
Nerve cell	<input type="checkbox"/>
Red blood cell	<input type="checkbox"/>

(1)

(b) Apart from the sex chromosomes, how many other chromosomes are there in most human body cells?

Tick one box.

21	<input type="checkbox"/>	23	<input type="checkbox"/>	44	<input type="checkbox"/>	46	<input type="checkbox"/>
----	--------------------------	----	--------------------------	----	--------------------------	----	--------------------------

(1)

Stickler syndrome is an inherited disorder that causes damage to the eye.

One of the symptoms of Stickler syndrome is that black spaces can appear in the visual image.

(c) Which part of the eye is affected by Stickler syndrome? Tick one box. **(triple only)**

Ciliary muscles	<input type="checkbox"/>
Iris	<input type="checkbox"/>
Retina	<input type="checkbox"/>

Suspensory ligaments



(1)

Stickler syndrome is caused by the inheritance of a dominant allele.

The diagram shows the inheritance of Stickler syndrome in two families.

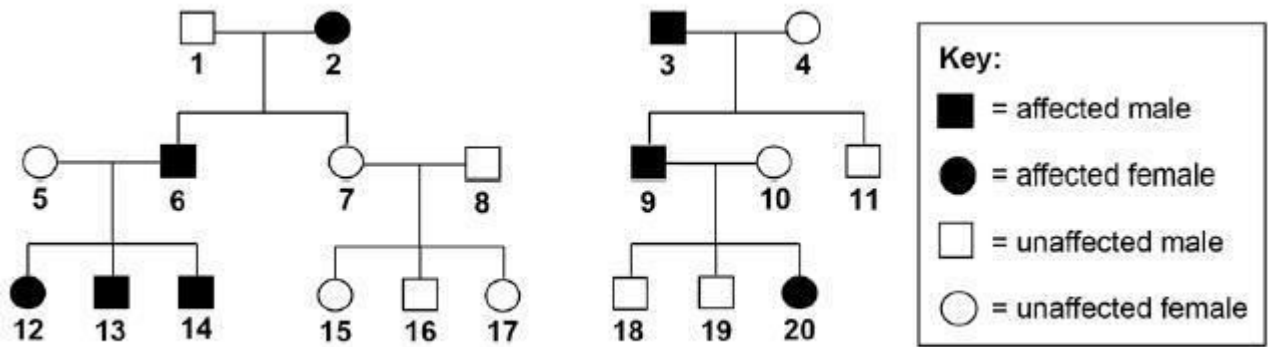

Use the following symbols in your answers to (d) and (e):

A = the dominant allele for Stickler syndrome
 a = the recessive allele for unaffected vision.

(d) Explain why none of the children of persons 7 and 8 have Stickler syndrome.

(2)

(e) Person 12 marries person 18.

Use a Punnett square diagram to find the probability that their first child will be a female with Stickler syndrome.

Probability of a female child with Stickler syndrome = _____

(4)

(Total 9 marks)

Q18.

Figure 1 shows a human body cell.

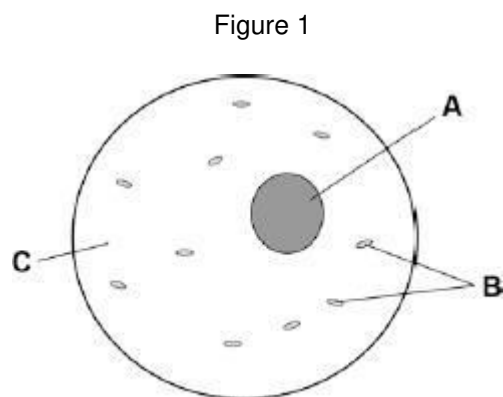

- (a) Which part in Figure 1 contains chromosomes? Tick one box.

A		B		C	
---	--	---	--	---	--

(1)

- (b) Humans have pairs of chromosomes in their body cells.

Draw one line from each type of cell to the number of chromosomes it contains.

Type of cell	Number of Chromosomes
	10
Human body cell	23
	46
Sperm cell	60
	92

(2)

- (c) Humans have two different sex chromosomes, X and Y.

Figure 2 shows the inheritance of sex in humans.

Figure 2

		Mother	
		X	X
Father	X	XX	XX
	Y	XY	XY

Circle a part of Figure 2 that shows an egg cell.

(1)

(d) Give the genotype of male offspring.

(1)

(e) A man and a woman have two sons. The woman is pregnant with a third child.

What is the chance that this child will also be a boy?

Tick one box.

0%

25%

50%

100%

(1)

(Total 6 marks)

Q19.

Our understanding of genetics and inheritance has improved due to the work of many scientists.

- (a) Draw one line from each scientist to the description of their significant work.

(triple only)

Scientist	Description of significant work
Charles Darwin	Carried out breeding experiments on pea plants.
Alfred Russel Wallace	Wrote 'On the origin of species'.
Gregor Mendel	Worked on plant defence systems.
	Worked on warning colouration in animals.

(3)

- (b) In the mid-20th century the structure of DNA was discovered.

What is a section of DNA which codes for one specific protein called? **(triple only)**

(1)

- (c) Figure 1 shows one strand of DNA.

The strand has a sequence of bases (A, C, G and T).

Figure 1

C T C A T T C A C C T G

How many amino acids does the strand of DNA in Figure 1 code for?

Tick one box. **(triple only)**

2

3	
4	
6	

(1)

(d) Mutations of DNA cause some inherited disorders. One inherited disorder is cystic fibrosis (CF).

A recessive allele causes CF.

Complete the genetic diagram in Figure 2.

- Identify any children with CF.
- Give the probability of any children having CF.

Each parent does not have CF.

The following symbols have been used:

D = dominant allele for not having CF

d = recessive allele for having CF

Figure 2

		Mother	
		D	d
Father	D	DD	
	d		

Probability of a child with CF = _____

(3)

(e) What is the genotype of the mother shown in Figure 2?

Tick one box.

Heterozygous

Homozygous dominant

Homozygous recessive



(1)
(Total 9 marks)

Q20.

Figure 1 shows an image of a small section of DNA.

Figure 2 shows the structure of a small section of DNA.

Figure 1



Figure 2

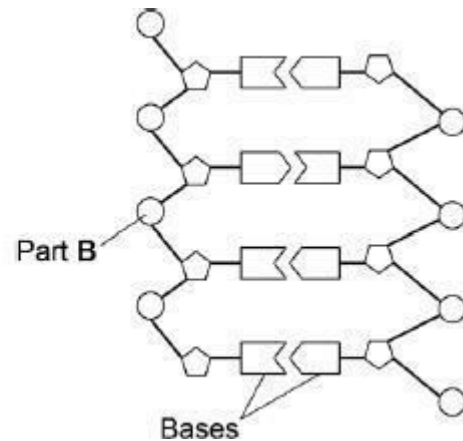

© Svisio/iStock/Thinkstock

- (a) What is Part B? **(triple only)**

(1)

- (b) In Figure 1 the structure of DNA shows four different bases.

There are four different bases and they always pair up in the same pairs. Which bases pair up together? **(triple only)**

(1)

- (c) Syndrome H is an inherited condition.

People with syndrome H do not produce the enzyme IDUA. Figure 3 shows part of the gene coding for the enzyme IDUA.

Figure 3

Q21.

In humans, hair colour is an inherited characteristic.

Red hair is caused by a recessive allele.

(a) When does a recessive allele control the development of a characteristic?

Tick (✓) one box.

When the allele is present on only one of the chromosomes.

When the dominant allele is not present.

When the allele is inherited from the female parent.

(1)

(b) Figure 1 shows the inheritance of hair colour in one family.

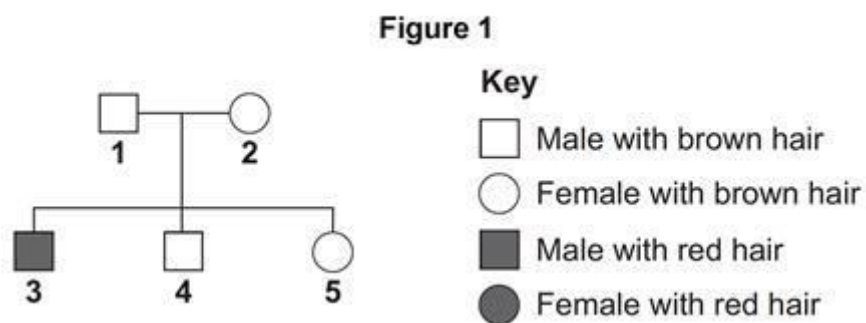

(i) Brown hair is caused by a dominant allele, B. Red hair is caused by the recessive allele, b. What combination of alleles does person 1 have?

Tick (✓) one box.

BB

Bb

bb

(1)

- (ii) Person 3 married a woman with brown hair.

Figure 2 shows how hair colour could be inherited by their children.

Figure 2

		Woman Brown hair	
		B	b
Person 3 Red hair	b	Bb	
	b		

Complete Figure 2 to show the combination of alleles that the children would inherit.
One has been done for you.

(2)

- (iii) What is the probability that one of the children would have red hair?

Tick (✓) one box.

1 in 2

1 in 3

1 in 4

(1)
(Total 5 marks)

Q22.

The diagram below shows the production of human sperm cells.

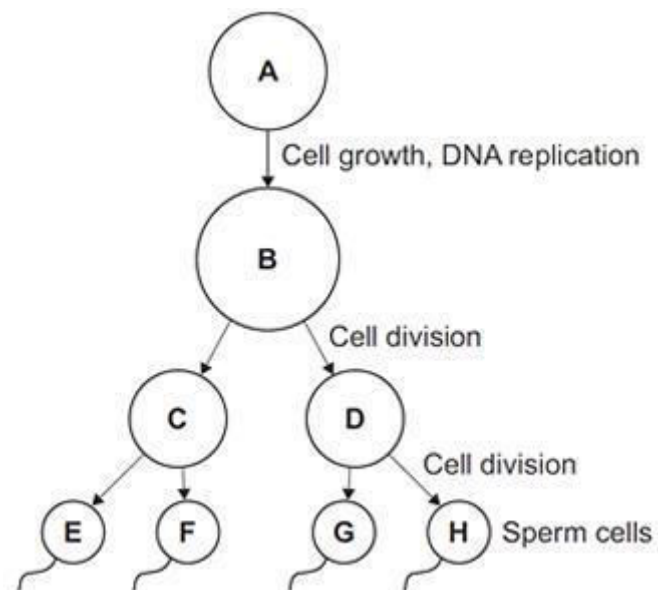

(a) Name the organ where the processes shown in the diagram above take place.

_____ (1)

(b) (i) Not every cell in the diagram above contains the same amount of DNA.

Cell A contains 6.6 picograms of DNA (1 picogram = 10⁻¹² grams).

How much DNA is there in each of the following cells?

Cell B _____ picograms

Cell C _____ picograms

Cell E _____ picograms

(2)

(ii) How much DNA would there be in a fertilised egg cell?

_____ picograms (1)

(iii) A fertilised egg cell divides many times to form an embryo.

Name this type of cell division.

_____ (1)

(c) After a baby is born, stem cells may be collected from the umbilical cord. These can be frozen and stored for possible use in the future.

(i) What are stem cells?

(2)

(ii) Suggest why it is ethically more acceptable to take stem cells from an umbilical cord instead of using stem cells from a 4-day-old embryo produced by In Vitro Fertilisation (IVF).

(1)

(iii) Stem cells taken from a child's umbilical cord could be used to treat a condition later in that child's life.

Give one advantage of using the child's own umbilical cord stem cells instead of using stem cells donated from another person.

(1)

(iv) Why would it not be possible to treat a genetic disorder in a child using his own umbilical cord stem cells?

(1)

(Total 10 marks)

Q23.

Polydactyly is an inherited condition caused by a dominant allele.

(a) The figure below shows the hand of a man with polydactyly. The man has an extra finger on each hand.

The man's mother also has polydactyly but his father does not.



© Ifness/iStock

- (i) The man is heterozygous for polydactyly.

Explain how the information given above shows that the man is heterozygous for polydactyly.

(3)

- (ii) The man marries a woman who does not have polydactyly. What is the probability that their first child will have polydactyly?

(1)

(b) The man has red hair. His sister has brown hair.

Both of their parents have brown hair.

Brown hair is caused by the dominant allele, B.

Red hair is caused by a recessive allele, b.

Complete the genetic diagram below to show how the man's parents were able to have some children with red hair and some with brown hair.

	Father	Mother
Parental phenotypes	_____	_____
Parental Genotypes	_____	_____
Gametes	_____	_____

Offspring genotypes: _____

Offspring phenotypes: _____

(5)

(Total 9 marks)